



KONICA MINOLTA

LIGHT METERS

ILLUMINANCE METER

LUMINANCE METER

UV RADIOMETER

CHROMA METER

T-10/T-10M/T-10Ws/T-10W_L
LS-100/LS-110
UM-10
CL-200
CS-100A

The essentials of imaging

ILLUMINANCE METER T-10 Series

**Accurate and Easy Measurement of Illuminance
Adapts To Various System Configurations
Modular Systems That Expand With Your Needs**

Illuminance Meter T-10 <standard receptor head>

Used for measurement of a wide range of illuminance

(0.01 to 299,900 lx)
(0.001 to 29,990 fcd)



T-10

Illuminance Meter T-10M <mini receptor head>

Used for measurement of illuminance that cannot be performed with the standard receptor head due to small spaces.

The measuring range is the same as T-10 (0.01 to 299,900 lx)
(ø14 mm receptor surface, 1 m cord) (0.001 to 29,990 fcd)



T-10M/T-10Ws/T-10WL

Illuminance Meter T-10Ws (5m cord) / T-10WL (10m cord)

Custom order

Since the mini receptor head and cord are waterproofed to allow measurement of illuminance under water, this product can be used for control of illuminance in the marine products industry (e.g. fish farming) and outdoor measurement of illuminance on rainy days.

WIDE RANGE OF APPLICATIONS

- Lighting engineers and specifiers
- R&D at light products manufacturers
- inspection of light sources at construction sites, government and educational facilities
- maintenance of lights in factories, offices, and hospitals
- electrical product manufacturers
- quality control of light sources at home
- agricultural and forestry industries.



Main Features

Provides multi functions and user-friendly features

For basic operation

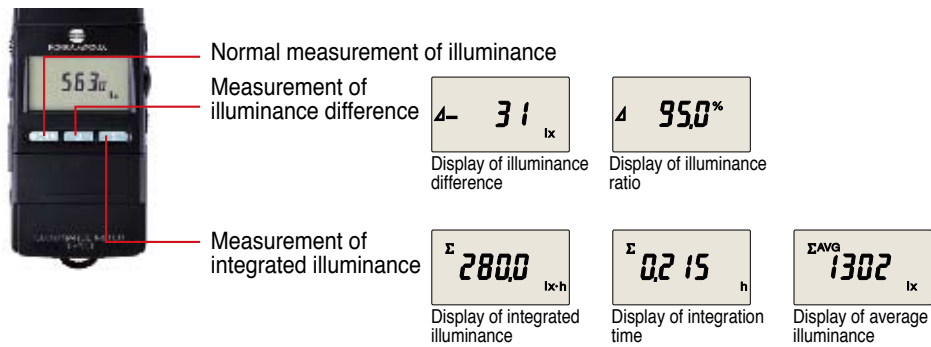

For advanced operation

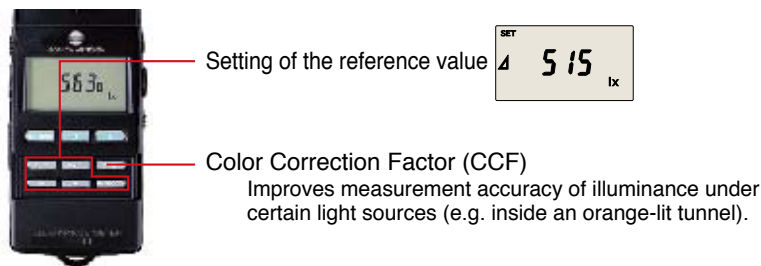

Allows connection with a personal computer and continuous recording of illuminance by a recorder

Digital output : Use of the RS232C interface (standard accessory) allows the meter to be connected to a personal computer.

Analog output : Allows the meter to be connected to a recorder for continuous recording of illuminance.

Quick automatic zero adjustment

Turning on the meter will perform zero adjustment (no cap required), allowing immediate measurement of illuminance.

Auto ranging

Range can also be set manually.

LCD back-light

The LCD back-light turns on automatically when illuminance is low.

Uses AA-size batteries.

Measures flickering light sources

Illuminance Measurement System to Meet Various Needs

Allows simple and low-cost multi-point measurement of illuminance (2 to 30 points).

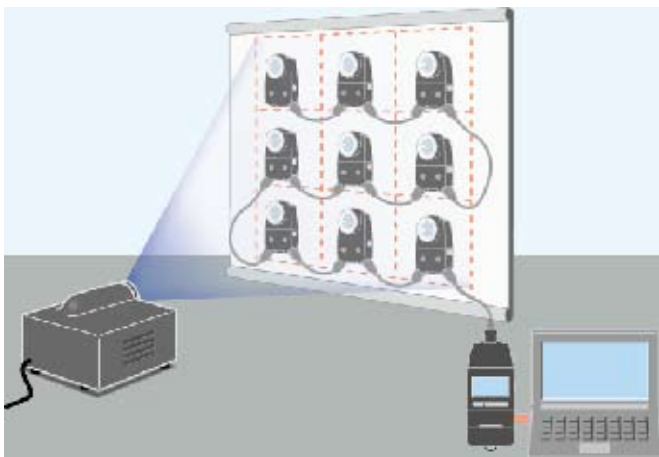

Multi-point illuminance measurement system (9 points)
For projector etc

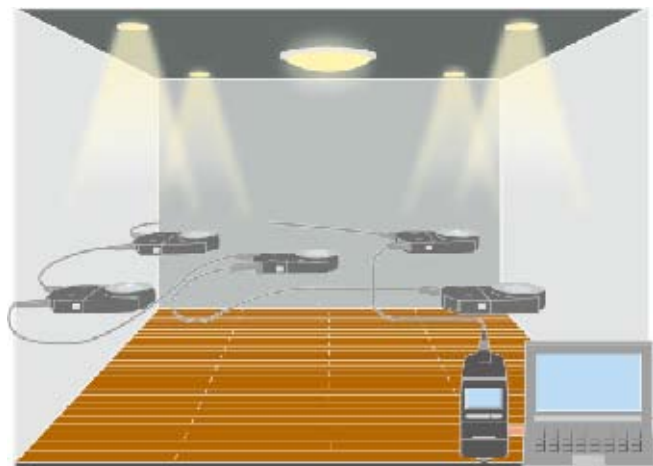

Multi-point illuminance measurement system (5 points)
For lighting at construction sites

Relative Spectral Response

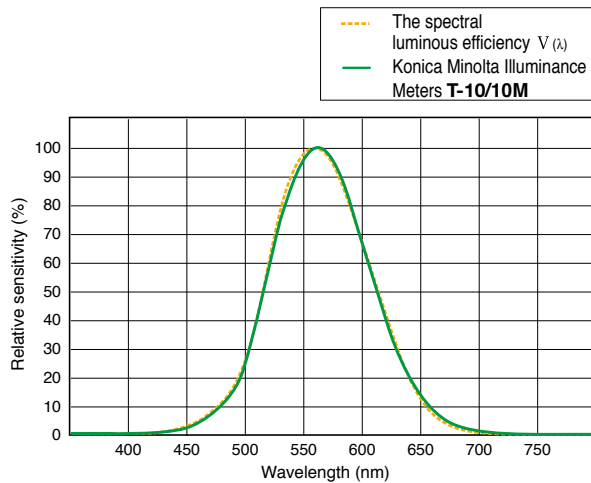

Ideally, the relative spectral responsivity of the illuminance meter should match $V(\lambda)$ of the human eye for photopic vision.

As shown in the graph at left, the relative spectral responsivity of Konica Minolta Illuminance Meters **T-10/10M** is within 6% (f_1) of the CIE spectral luminous efficiency $V(\lambda)$.

CIE ; Commission Internationale de l'Eclairage

f_1 (CIE's symbol) ; The degree to which the relative spectral responsivity matches $V(\lambda)$ is characterized by means of the error f_1 .

Cosine Correction Characteristics

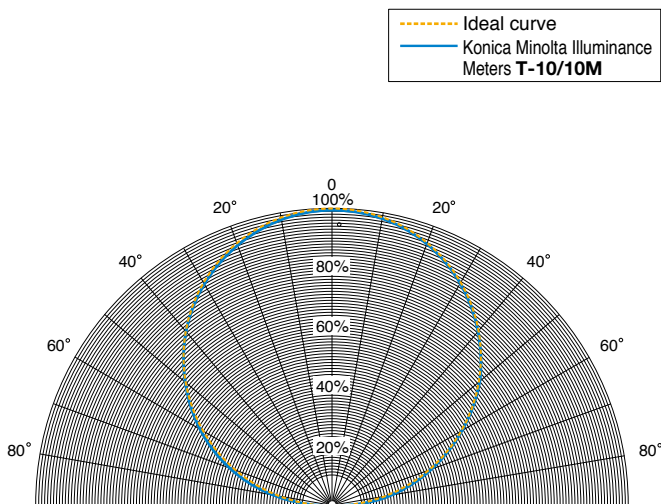

Since the brightness at the measurement plane is proportional to the cosine of the angle at which the light is incident, the response of the receptor must also be proportional to the cosine of the incidence angle.

For Konica Minolta Illuminance Meters **T-10/10M**, the cosine response f_2 is within 3%.

The graph at left shows the cosine correction characteristics of Konica Minolta Illuminance Meters **T-10/10M**.

The cosine error of **T-10/10M** are shown in the table right.

Incidence angle (deg.)	Cosine error (within)
10°	± 1%
30°	± 2%
50°	± 6%
60°	± 7%
80°	± 25%

For a photometer head in an illuminance meter, the deviation in the directional response to the incident radiation is characterized by $f_2(\epsilon, \varphi)$:

$$f_2(\epsilon, \varphi) = \frac{Y(\epsilon, \varphi)}{Y(0, \varphi) \times \cos \epsilon} - 1$$

where

$Y(\epsilon, \varphi)$ is the signal output as a function of the angle of incidence;

ϵ is measured with respect to the normal to the measuring plane or optical axis;

φ is the Azimuth angle.

For characterizing the directional response error by a single factor the characteristic f_2 is used:

$$f_2 = \int_0^{85^\circ - \frac{\pi}{180}} |f_2(\epsilon)| \times \sin 2\epsilon \, d\epsilon$$

SYSTEM DIAGRAM

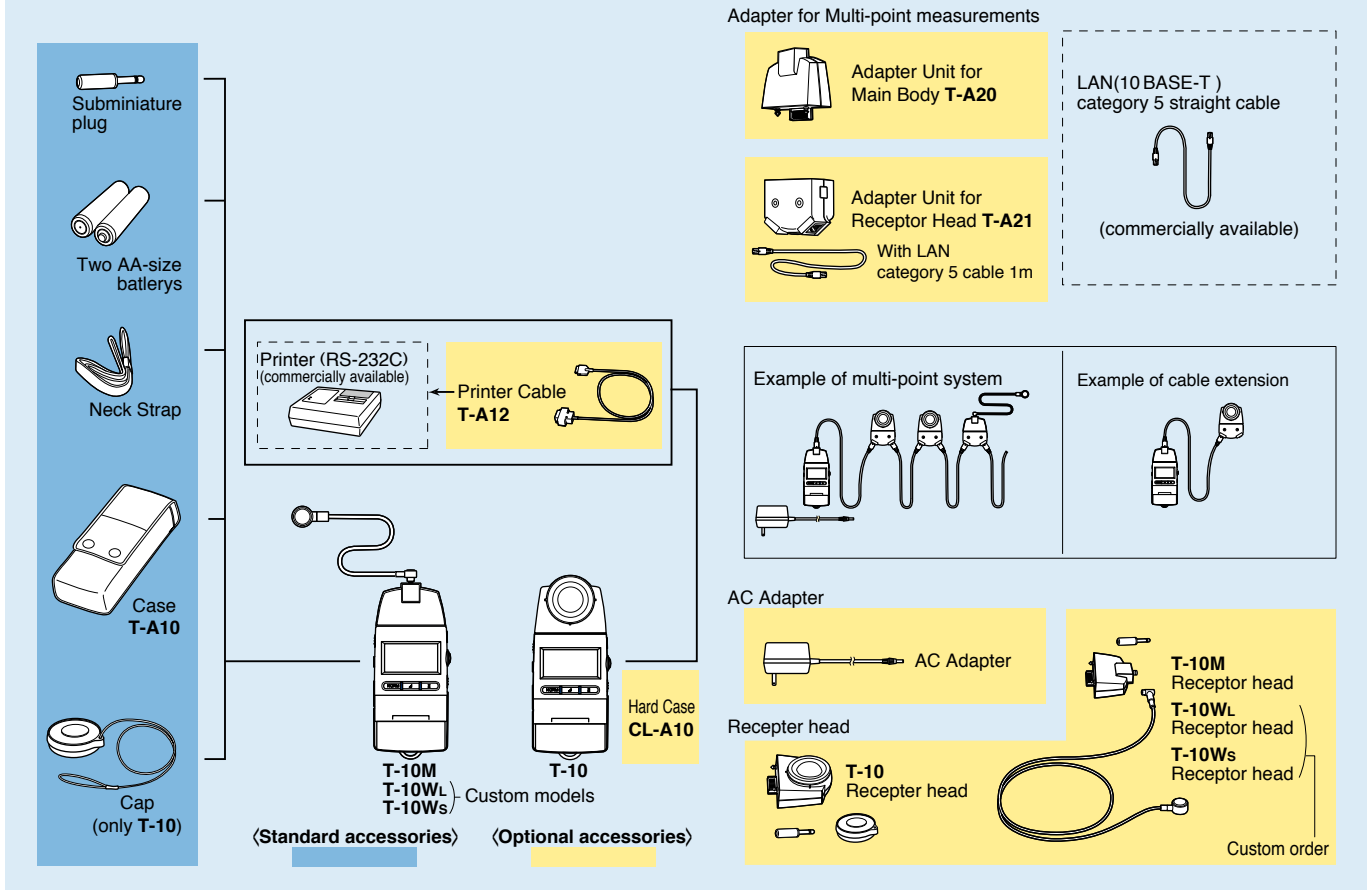

SPECIFICATIONS

Model	Illuminance meter T-10 <standard receptor head>	Illuminance meter T-10M <mini receptor head>
Type	Multi-function digital illuminance meter with detachable receptor head	
Receptor	Silicon photocell	
Relative Spectral Response	Within 6% (f1') of the CIE spectral luminous efficiency V (λ)	
Cosine response (f ₂)	Within 3%	
Cosine Correction Characteristics	Within ±1% at 10° ; Within ±2% at 30° ; Within ±6% at 50° ; Within ±7% at 60° ; Within ±25% at 80°	
Illuminance units	Lux (lx) or foot candles (fcd) (switchable)	
Measuring range	Auto range (manual 5 range at the time of analog output)	
Measuring function	Illuminance(lx). illuminance difference(lx). illuminance ratio(%). integrated illuminance(lx·h). integration time(h). average illuminance(lx).	
Measuring range	Illuminance..... 0.01 to 299,900 lx 0.001 to 29,990 fcd Integrated illuminance..... 0.01 to 999,900 x 10 ³ lx·h 0.001 to 99,990 x 10 ³ fcd·h / 0.001 to 9999 h	
User calibration function	CCF(Color Correction Factor) setting function	
Linearity	±2% ±1digit of displayed value (based on Konica Minolta standard)	
Temperature/humidity drift	Within ±3% ±1digit (of value displayed at 20°C/68°F) within operating temperature/humidity range	
Digital output	RS-232C	
Analog output	1mV/digit,3V at maximum reading; Output impedance: 10KΩ; 90% response time: FAST setting: 1ms, SLOW setting: 1s	
Display	3 or 4 Significant-digit LCD with back-light illumination	
Operating temperature /humidity range	-10 to 40°C, relative humidity 85% or less (at 35°C) with no condensation	
Storage temperature /humidity range	-20 to 55°C, relative humidity 85% or less (at 35°C) with no condensation	
Power source	2 AA-size batteries / AC adapter (optional)	
Battery life	72 hours or longer (when alkaline batteries are used) in continuous measurement	
Dimensions	69 x 174 x 35 mm (2-6/16x6-14/16x1-7/16 in.)	Main body : 69 x 161.5 x 30 mm (2-6/16x6-6/16x1-3/16 in.) Receptor : ø16.5 x 12.5 (ø11/16 x 1/2 in.) Cord length : 1m (3.3 in.)
Weight	200g (7.0 oz.) without battery	205g (7.2 oz.) without battery
Standard accessories	ø3.5mm(ø1/8 in.) subminiature plug for analog output ; Receptor cap ; Neck strap ; Case ; Battery	ø3.5mm(ø1/8 in.) subminiature plug for analog output ; Neck strap ; Case ; Battery
Optional accessories	Receptor head ; Adapter for Multi-point ; AC Adapter	

Specifications are subject to change without notice.

LUMINANCE METERS LS-100/LS-110

Compact, lightweight, easy-to-use SLR luminance meters with a wide measuring range

Luminance Meter LS-100

1° acceptance angle,
Measuring range: 0.001 to 299,900cd/m²
(0.001 to 87,530fL)

Luminance Meter LS-110

1/3° acceptance angle,
Measuring range: 0.01 to 999,900cd/m²
(0.01 to 291,800fL)



LS-100

MAIN FEATURES

Flareless SLR optical system for accurate measurements

The SLR (single-lens-reflex) optical system allows precise aiming and ensures that the viewfinder shows the exact area to be measured. The optical system is also virtually flareless, eliminating the influence of light from outside the measurement area.

Narrow acceptance angle for measurements of small specimens

Acceptance angles of only 1° for **LS-100** and 1/3° for **LS-110** allow accurate measurements of small specimen areas. In addition, optional close-up lenses can be used to measure areas as small as ø1.3mm when using **LS-100** and ø0.4mm when using **LS-110**.

User calibration and color-correction functions

To increase the versatility of the **LS-100** and **LS-110**, both models are equipped with user calibration and color correction functions. The user calibration function allows the meter to be calibrated to a user-selected standard instead of the preset Konica Minolta standard; this function can also be used to standardize the response of several meters. The color correction function allows the response of the meter to be adjusted when measuring colored specimens.

Luminance ratio and peak luminance measurements

In addition to measurements of the present luminance, the **LS-100** and **LS-110** can also determine the percent ratio of the measured luminance to a luminance value stored in memory as well as the peak luminance or luminance ratio measured.

RS-232C data communication

Use of the built-in RS-232C interface allows the meter to be connected to a personal computer.

Lightweight, compact design powered by a single 9V battery for portability

(Power can also be supplied by optional Data Printer **DP-10**.)

RELATIVE SPECTRAL RESPONSE

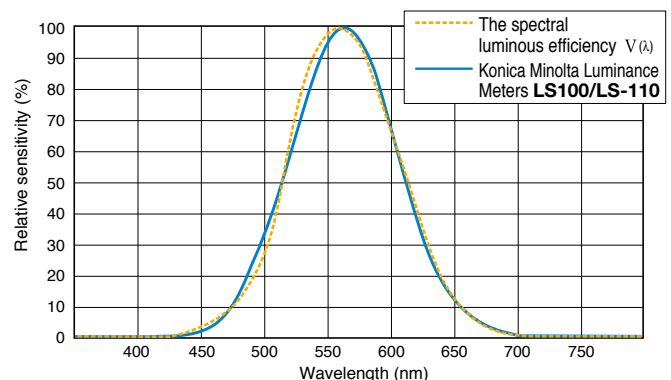

Ideally, the relative spectral responsivity of the luminance meter should match $V(\lambda)$ of the human eye for photopic vision. As shown in the graph above, the relative spectral responsivity of Konica Minolta Luminance Meters **LS-100/LS-110** is within 8% (f1') of the CIE spectral luminous efficiency $V(\lambda)$.

CIE ; Commission Internationale de l'Éclairage
f1'(CIE-s symbol) ; The degree to which the relative spectral responsivity matches $V(\lambda)$ is characterized by means of the error f1'.

REDUCTION OF FLARE

The degree to which the influence of light from outside the defined measuring area is eliminated is an important factor in the performance of luminance meters. In Konica Minolta Luminance Meters, the flare factor is kept to below 1.5%, even if an object with extremely high luminance is just outside the meter's measuring area. The graph at right shows the effect when a bright point is moved from A inside the measuring area to B just outside the measuring area.

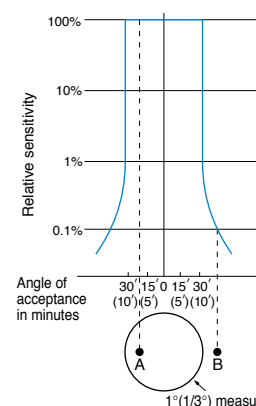

If the measured value at A is defined at 100%, the measured value at B would be less than 0.1%.

SPECIFICATIONS

Model	Luminance Meter LS-100	Luminance Meter LS-110
Type	SLR spot luminance meter for measuring light-source and surface brightness	
Measuring angle	1°	1/3°
Optical system	85mm f/2.8 lens; SLR viewing system; flare factor less than 1.5%	
Angle of view	9°	
Focusing distance	1014mm (40 in.) to infinity	
Minimum measuring area	ø14.4mm	ø4.8mm
Receptor	Silicon photocell	
Relative Spectral Response*	Within 8% (f1') of the CIE spectral luminous efficiency V (λ)	
Response time	FAST: Sampling time: 0.1s, time to display: 0.8 to 1.0s; SLOW: Sampling time: 0.4s, time to display: 1.4 to 1.6s	
Luminance units	cd/m ² or fL (switchable)	
Measuring range	FAST: 0.001 to 299,900cd/m ² (0.001 to 87,530fL) SLOW: 0.001 to 49,990cd/m ² (0.001 to 14,590fL)	FAST: 0.01 to 999,900cd/m ² (0.01 to 291,800fL) SLOW: 0.01 to 499,900cd/m ² (0.01 to 145,900fL)
Accuracy	0.001 to 0.999cd/m ² (or fL): ±2% ±2 digits of displayed value 1.000cd/m ² (or fL) or greater: ±2% ±1 digit of displayed value (Illuminant A measured at ambient temperature of 20 to 30°C/68 to 86°F)	0.01 to 9.99cd/m ² (or fL): ±2% ±2 digits of displayed value 10.00cd/m ² (or fL) or greater: ±2% ±1 digit of displayed value
Repeatability	0.001 to 0.999cd/m ² (or fL): ±0.2% ±2 digits of displayed value 1.000cd/m ² (or fL) or greater: ±0.2% ±1 digit of displayed value (Measurement subject: Illuminant A)	0.01 to 9.99cd/m ² (or fL): ±0.2% ±2 digits of displayed value 10.00cd/m ² (or fL) or greater: ±0.2% ±1 digit of displayed value
Temperature/humidity drift	Within ±3% ±1 digit (of value displayed at 20°C/68°F) within operating temperature/humidity range	
Calibration mode	Minolta standard/user-selected standard (switchable)	
Color correction factor	Set by numerical input; range: 0.001 to 9.999	
Reference luminance	1; set by measurement or numerical input	
Measurement modes	Luminance; luminance ratio; peak luminance or luminance ratio	
Display	External: 4-digit LCD with additional indications Viewfinder: 4-digit LCD with LED backlight	
Data communication	RS-232C; baud rate: 4800bps	
External control	Measurement process can be started by external device connected to data output terminal	
Power source	One 9V battery; power can also be supplied by optional Data Printer DP-10	
Power consumption	While measuring button is pressed and viewfinder display is lit: 16mA average While power is on and viewfinder display is not lit: 6mA average	
Operating temperature/humidity range	0 to 40°C, relative humidity 85% or less (at 35°C) with no condensation	
Storage temperature /humidity range	-20 to 55°C, relative humidity 85% or less (at 35°C) with no condensation	
Dimensions	79x208x150mm (3-1/8x8-3/16x5-7/8 in.)	
Weight	850g (30 oz.) without battery	
Standard accessories	Lens cap; Eyepiece cap; ND eyepiece filter; 9V battery; Case	

Specifications are subject to change without notice.

OPTIONAL ACCESSORIES

SYSTEM DIAGRAM (Optional Accessories)

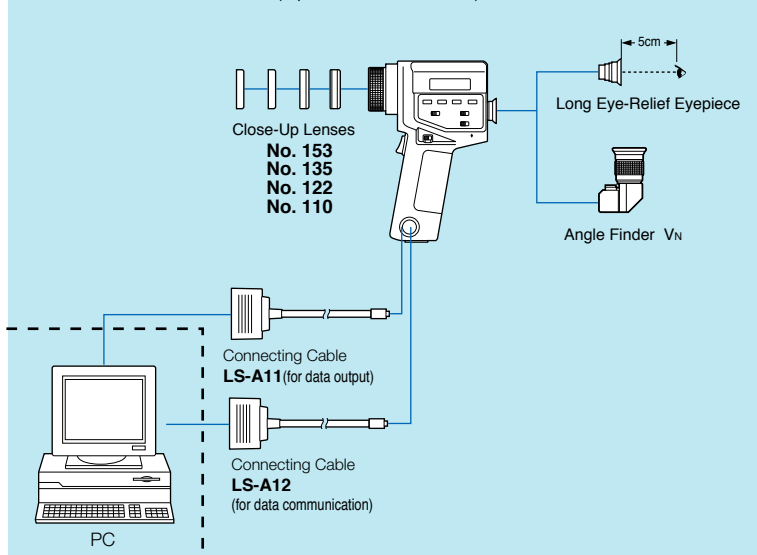

Close-Up Lenses



Close-Up Lenses	Minimum measuring area	
	With LS-100	With LS-110
No. 153	ø8.0mm	ø2.7mm
No. 135	ø5.2mm	ø1.8mm
No. 122	ø3.2mm	ø1.1mm
No. 110	ø1.3mm	ø0.4mm

Long Eye-Relief Eyepiece



When the Long Eye-Relief Eyepiece is used, the measuring area and measurement display inside the viewfinder can be seen with the eye 5cm (2 in.) away from the eyepiece.

Angle Finder Vn



Angle Finder Vn allows the measuring area and measurement display inside the viewfinder to be seen at an angle of 90° to the normal viewfinder optical axis. Angle Finder Vn can also be focused and the magnification can be set to 1x or 2x.

UV RADIOMETER UM-10

An easy-to-use instrument for measuring ultraviolet radiation. Choose from three different high-sensitivity receptor heads according to your application.



MAIN FEATURES

Easy operation

Wide total measuring range (0.1 to 199,900 $\mu\text{W}/\text{cm}^2$) with automatic range selection

Choice of three different receptor heads to match specific applications

Compact, handheld design

Digital (RS-232C) and analog output terminals

MAIN APPLICATIONS

Fields Utilizing Photochemical Reactions

- Checking exposure of photoresists in semiconductor manufacturing
- Checking exposure of emulsions for printing or platemaking
- Testing fading due to UV exposure
- Evaluating characteristics of solar cells
- Testing deterioration of products due to UV exposure

Fields Utilizing Biological Applications of UV Exposure

- Diagnosis of erythema and other skin pigmentation problems
- Treatment of white skin spots or oversensitivity to light
- Optimization and control of breeding conditions for fish and domestic animals
- Suppressing growth of useless shoots on plants
- Monitoring conditions for photosynthesis

Fields Utilizing the Photoelectric Effect

- Electrophotography
- Electrographic etching

Fields Requiring Use of Sterilization Lamps

- Food processing
- Beauty treatment
- Scientific research

Other fields which require adjustment, monitoring, or research of ultraviolet light and light sources

THREE DIFFERENT RECEPTOR HEADS

Receptor Head UM-250 (220 to 300nm) **Receptor Head UM-360 (310 to 400nm)** **Receptor Head UM-400 (360 to 480nm)**

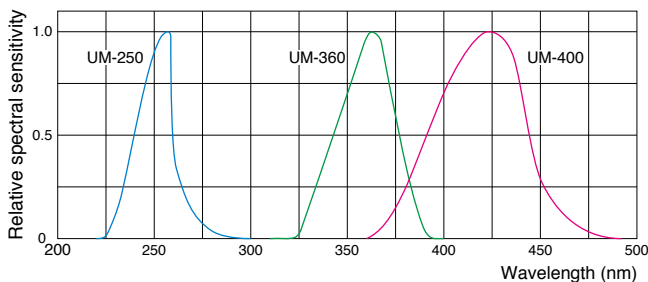

EXAMPLES OF SUBJECT LIGHT SOURCES

- Fluorescent health lamps
- High-pressure mercury lamps
- Ultra-high-pressure mercury lamps
- Photopolymerization lamps
- Blacklight lamps
- Copier lamps
- Xenon lamps
- Fluorescent lamps
- Sterilization lamps

EXAMPLES OF SUBJECT LIGHT SOURCES

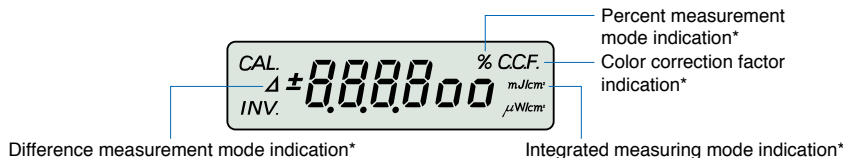

* Available only when optional Expansion Keyboard **UM-A25** is attached.

OPTIONAL ACCESSORIES



Expansion Keyboard UM-A25

With Expansion Keyboard **UM-A25** attached, the following functions are added.

Integrated irradiance

The total irradiance received over a period of time can be measured.
 Maximum integrated irradiance
 Approx. 1,000,000,000mJ/cm
 Maximum integration time: 999.900sec

Color correction factor

By setting the appropriate color correction factor, the **UM-10** can be adjusted to more accurately measure the irradiance of different lamp types.

Irradiance difference

The difference between a measured irradiance and a target irradiance* stored in memory can be determined.

Percent irradiance

The measured irradiance as a percentage of a target irradiance* stored in memory can be determined.

*The target irradiance can be measured or input as numerical values.

SYSTEM DIAGRAM

(Optional Accessories)

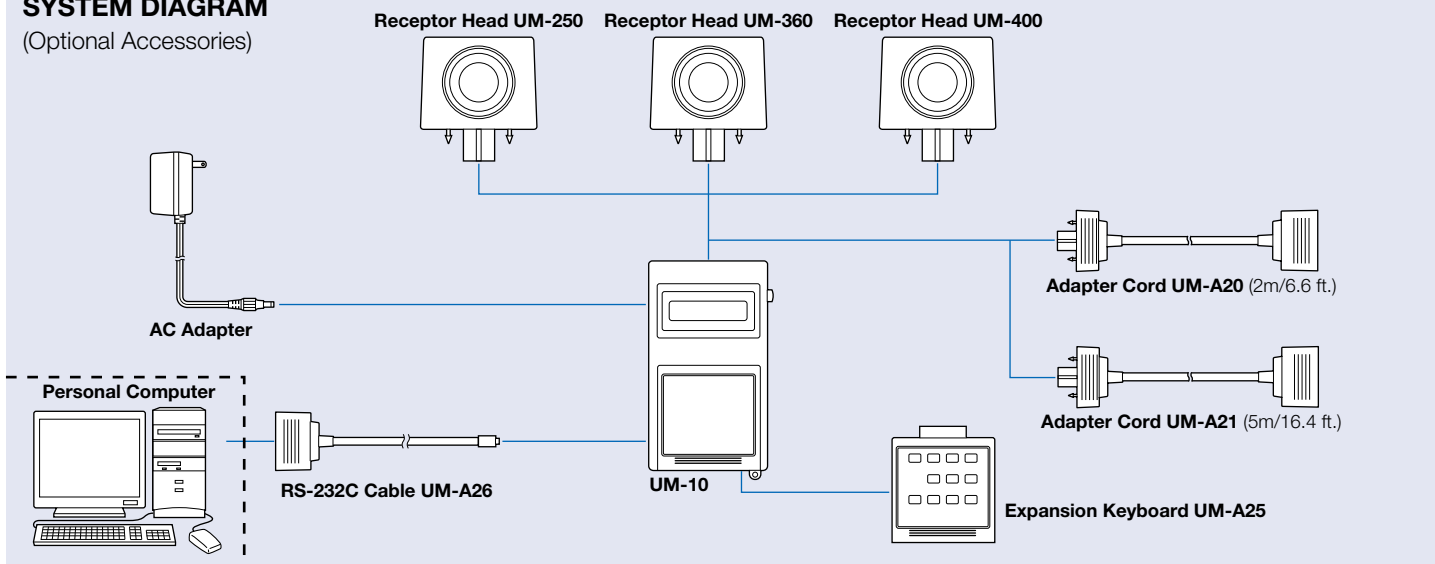

SPECIFICATIONS

Type	Irradiance meter with interchangeable receptor heads for measuring UV radiation			
Receptor heads	Receptor	Silicon photodiode		
	Model	UM-250	UM-360	UM-400
	Spectral response	220 to 300nm	310 to 400nm	360 to 480nm
	Peak wavelength	250±10nm	365±5nm	415±5nm
Cosine error	30°	Within ±3%	Within ±3%	Within ±3%
	60°	Within ±15%	Within ±10%	Within ±10%
Measurement modes	Irradiance ;integrated irradiance*and integration time*;irradiance difference*;percent irradiance*			
Irradiance measuring range	0.1 to 199,900μW/cm ² in four automatically selected ranges			
Integrated irradiance range*	Maximum approx.100000mJ/cm ² measurable (in 9999 display cycles)			
Integration time*	999,900sec.(288h)			
Linearity	Within ±5% of reading = 1 digit			
Temperature/humidity drift	Within ±3% ±1 digit (of value displayed at 23°C/73.4°F) within operating temperature/humidity range			
Analog output	0 to 3V;1mV/digit			
Digital output	RS-232C 2400BPS			
Display	4-digit LCD			
Operating temperature/humidity range	0 to 40°C, relative humidity 85% or less (at 35°C) with no condensation			
Storage temperature/humidity range	-20 to 55°C, relative humidity 85% or less (at 35°C) with no condensation			
Power source	One 9V battery or optional AC adapter			
Dimensions	73.5X186X33mm(2-7.8X7-5/16X1-5/16 in)			
Weight	270g(9.5 oz.) including battery			
Standard accessories	Case;Cap;Strap;Analog output plug			

*Available only with optional Expansion Keyboard **UM-A25** attached.
 Specifications are subject to change without notice.

CHROMA METER CL-200

Enables measurement of tristimulus values, chromaticity, color difference, correlated color temperature and illuminance of light sources.



MAIN FEATURES

Four types of calibration functions for correcting measurement values:

Normal Calibration : Corrects measurement values for Standard Illuminant A as the calibration light source

Normal User Calibration : Corrects measurement values for input calibration light source values

Multi Calibration : Corrects measurement values for the R/G/B/W values of ultra-high-pressure mercury lamps

Multi User Calibration : Corrects measurement values for input calibration light source values for R/G/B/W

- Input of R/G/B/W values for Multi User Calibration requires Data Processing Software CL-S1w,(sold separately)

Enables multi-point measurement

Allows simple and low-cost multi-point measurement. Up to 30 receptors can be connected to one main body.

Simple operation

- Turning on the meter will perform zero adjustment (no cap required), allowing immediate measurement.
- Keys that are not used frequently can be placed under a sliding cover, to prevent pressing a key in error and to give the operating panel a neat appearance.

Other features

- The receptor can be separated and then connected to the main body with a LAN cable. This allows the user to install the receptor up to 100m from the main body and control it remotely. (For this, optional adapters T-A20 (for main body) and T-A21 (for receptor) are required.)
- Use of the built-in RS232C interface allows the meter to be connected to a personal computer. (For RS-232C interface, an optional cable (T-A11) is available.)
- Connecting to a commercially available thermal printer allows printout of measured data. (For connecting to a printer, an optional printer cable (T-A12) is available.)
- The LCD back-light turns on automatically when illuminance is low.
- Powered by AA-size batteries or optional AC adapter.
- This optional PC software offers several desirable features (e.g. easy operation, visual data display, and flexible data processing). This software provides multi-point graphical data.

MAIN APPLICATIONS

- R&D and color inspection of light sources in a variety of industries, eg, lamp manufacturers, building and interior design.
- Setting up projectors for presentation purposes.
- Color adjustment of CRTs, flat panel and other display devices.
- Color evaluation and control of light boxes and light booths.
- Evaluating color in an experimental environment for psychology.

Illuminance measurement system to meet various needs

Allows simple and low-cost multi-point measurement (2 to 30 points).

Up to 30 receptors can be connected to one main body. (For multi-point measurement, optional adapters T-A20 (for main body) and T-A21 (for receptor) are required.)

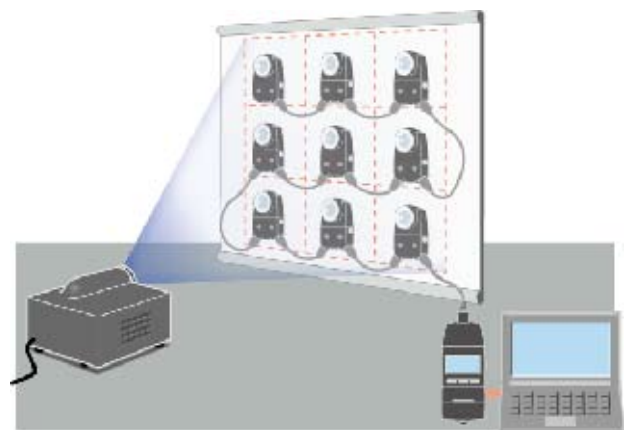

DIMENSIONS

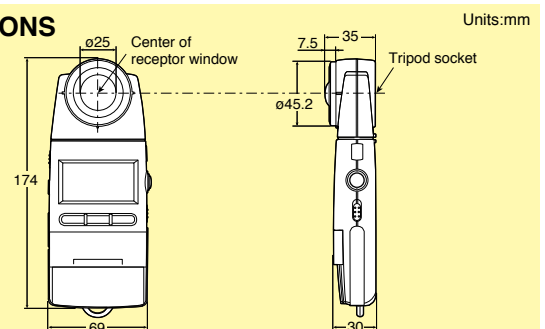

<Illuminance Measurement Performance>

– Relative Spectral Response –

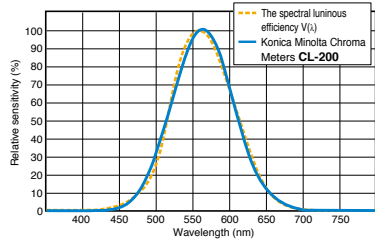

Ideally, the relative spectral responsivity of the illuminance meter should match $V(\lambda)$ of the human eye for photopic vision. As shown in the graph above, the relative spectral responsivity of Konica Minolta Chroma Meters **CL-200** is within 8% (f_1') of the CIE spectral luminous efficiency $V(\lambda)$.

CIE : Commission Internationale de l'Eclairage
 f_1' (CIE's symbol) : The degree to which the relative spectral responsivity matches $V(\lambda)$ is characterized by means of the error f_1' .

– Cosine Correction Characteristics –

Since the light at the measurement plane is proportional to the cosine of the angle at which the light is incident, the response of the receptor must also be proportional to the cosine of the incidence angle.

The graph above shows the cosine correction characteristics of Konica Minolta Chroma Meters **CL-200**.

The cosine error of **CL-200** is shown in the table right.

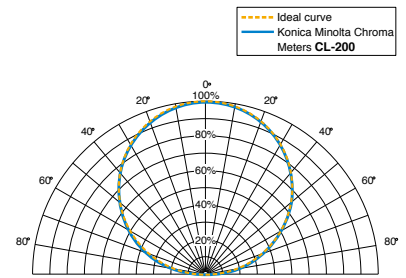

<Chromaticity and Color Temperature>

– Chromaticity (xy) –

XYZ tristimulus values and the associated Yxy color space form the foundation of the present system for numerical color notation. The concept for the XYZ tristimulus values is based on the premise that all colors are seen as mixtures of these three primary colors. By defining the color matching functions of a Standard Observer, the Commission Internationale de L'Eclairage (CIE), an international organization concerned with light and color, provided the basis for colorimetry in 1931.

The tristimulus values XYZ are useful for specifying a color, but the results are not easily visualized. The two-dimensional color (x,y) diagram is taken from the Yxy color space, in which Y is the lightness (and is identical to the tristimulus value Y) and x and y are the chromaticity coordinates calculated from the tristimulus values XYZ. The CIE x, y chromaticity diagram for this color space is shown. In this diagram, achromatic colors are toward the center of the diagram, and the chroma or saturation increases toward the edges.

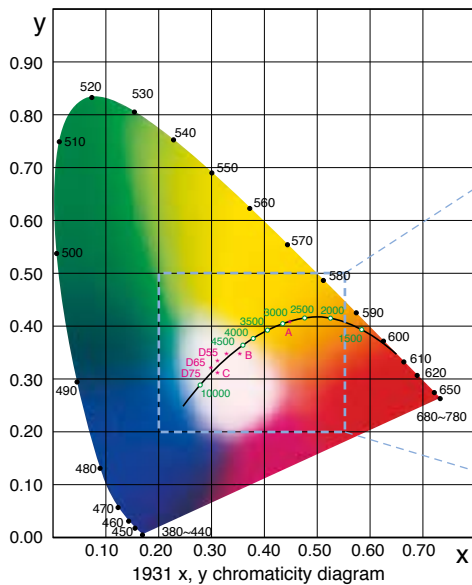

– Color Temperature (Tcp) –

A black body (perfect radiant body) is an ideal object that absorbs all energy, changes its color from red through yellow to white as its temperature increases. The absolute temperature T (K) of the black body is referred to as the color temperature. The xy chromaticity diagram given on the left shows the relationship between the temperature and color by a locus (black body locus).

The diagram given below is sometimes used to indicate the color of a light source. Correlated color temperature is used to apply the general idea of color temperature to those colors that are close to, but not exactly on the blackbody locus. For instance, a light source which has a color difference of 0.01 in the green direction (Δuv) from a black body which has a color temperature of 7,000K is indicated as having a correlated color temperature of 7,000K + 0.01 (uv unit).

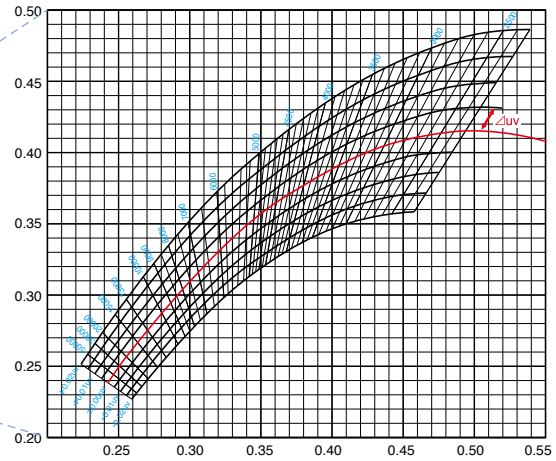

xy chromaticity chart indicating the black body locus, the isotherm lines and equal Δuv lines.

SPECIFICATIONS

Relative Spectral Response	Closely matches CIE Standard Observer curves $\bar{x}(\lambda)$, $\bar{y}(\lambda)$, and $\bar{z}(\lambda)$ Within 6% (f_1') of the CIE spectral luminous efficiency $V(\lambda)$
Cosine response (f_2')	Ev : Within 3%
Receptor	Silicon photocell
Measuring function	Tristimulus values : XYZ Chromaticity : Ev xy, Ev u'v' Correlated color temperature : Ev, Tcp, Δuv Color difference : $\Delta(XYZ)$, $\Delta(Ev xy)$, $\Delta(Ev u'v')$, $\Delta Ev \Delta u'v'$
Other function	User calibration function, Data hold function, Multi-point measurement (2 to 30 points)
Measuring range	0.1~99,990 lx, 0.01~9,999 fcd (Chromaticity : 5 lx, 0.5 fcd or above) in four automatically selected ranges (lx or fcd is switchable)
Accuracy	Ev : $\pm 2\% \pm 1$ digit of displayed value (based on Minolta Standard) xy : ± 0.002 (800 lx, standard illuminant A measured)
Repeatability	Ev : 0.5% +1 digit (2 σ) (800 lx, standard illuminant A measured) xy : ± 0.0005 (A measured)
Temperature drift	Ev : $\pm 3\% \pm 1$ digit of displayed value, xy : ± 0.003
Humidity drift	Ev : $\pm 3\% \pm 1$ digit of displayed value, xy : ± 0.003
Response time	0.5 sec. (continuous measurement)
Digital output	RS-232C
Display	4 Significant-digit LCD with back-light illumination
Operating temperature /humidity range	-10 to 40°C, relative humidity 85% or less (at 35°C) with no condensation
Storage temperature /humidity range	-20 to 55°C, relative humidity 85% or less (at 35°C) with no condensation
Power source	2 AA-size batteries / AC adapter (optional)
Battery life	72 hours or longer (When alkaline batteries are used) in continuous measurement
Dimensions	69x174x35mm (2-6/16x6-14/16x1-7/13 in.)
Weight	215g (7.6 oz.) not including batteries

Specifications are subject to change without notice.

SYSTEM DIAGRAM

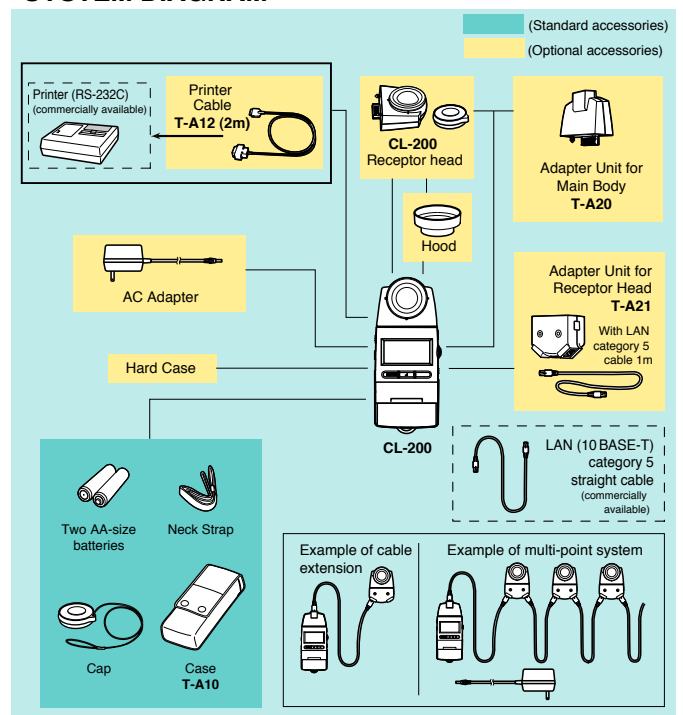

CHROMA METER CS-100A

A compact, lightweight, battery-powered instrument with a 1° measurement angle for high-accuracy non-contact measurements of the luminance and chromaticity of light sources and reflective subjects



EASY-TO-READ DISPLAY

Viewfinder Image

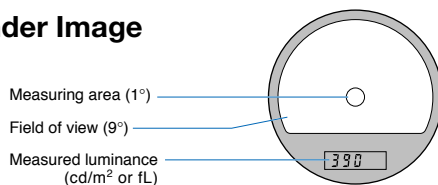

External display



MAIN FEATURES

Compact and lightweight

Measurements of subjects at a distance

SLR (single-lens-reflex) viewing system and flare-free optical system provide accurate measurements of subjects at a distance with virtually no influence from light outside the measurement area

Measurements of small subjects

1° measurement angle allows measurements of subjects as small as $\phi 14.4\text{mm}$ (at a subject distance of 1014mm); by using optional Close-Up Lenses, subjects as small as $\phi 1.3\text{mm}$ can be measured.

Color difference can also be measured

Calibration to a user-selected reference is also possible

Luminance units of cd/m^2 or fL can be selected

MAIN APPLICATIONS

Light-Source Measurements

- Luminance and chromaticity of small light sources such as LEDs, miniature neon lamps, etc.
- Luminance and chromaticity of general light sources such as tungsten lamps, fluorescent lamps, etc.
- Luminance and chromaticity of traffic signals, airport guidance lights, emergency exit signs, etc.

Reflective-Subject Measurements

- Color measurements of subjects which cannot be measured by contact methods, such as distant building walls, just-painted surfaces, subjects with complicated shapes, or subjects which should not be touched for sanitary reasons.

Display Measurements

- Luminance and chromaticity of color TVs and CRTs
- Luminance measurements of monochrome TVs and SRTs
- Luminance and chromaticity of projection TVs and video projectors.



SPECIFICATIONS

Model	Chroma Meter CS-100A
Type	SLR spot colorimeter for measuring light-source and surface luminance and chromaticity
Measuring angle	1°
Optical system	85mm f/2.8 lens; SLR viewing system; flare factor less than 1.5%
Angle of view	9° with 1° measurement area indication
Focusing distance	1014mm (40 in.) to infinity
Receptors	3 silicon photocells filtered to detect primary stimulus values for red, green and blue light
Spectral response	Closely matches CIE 1931 Standard Observer curves ($\bar{x}(\lambda)$, $\bar{y}(\lambda)$, and $\bar{z}(\lambda)$)
Response time	FAST: Sampling time: 0.1s, Time to display: 0.8 to 1.0s; SLOW: Sampling time: 0.4s, Time to display: 1.4 to 1.6s
Luminance units	cd/m ² or fL (switchable)
Measuring range	FAST: 0.01 to 299,000cd/m ² (0.01 to 87,530fL); SLOW: 0.01 to 49,900cd/m ² (0.01 to 14,500fL)
Accuracy	Luminance (Y): $\pm 2\%$ of reading ± 1 digit Chromaticity (x,y): ± 0.004 (Illuminant A measured at ambient temperature of 18 to 28°C/64 to 82°F)
Repeatability	Luminance (Y): $\pm 0.2\%$ of reading ± 1 digit Chromaticity (x,y) : FAST: Y 100cd/m ² or above: ± 0.001 ; 48.1 to 99.9cd/m ² : ± 0.002 ; below 48.1cd/m ² : below measurement range SLOW: Y 25.0cd/m ² or above: ± 0.001 ; 12.0 to 24.9cd/m ² : ± 0.002 ; below 12.0cd/m ² : below measurement range (Measurement subject: Illuminant A)
Target value	1; set by measurement or numerical input
Measurement modes	Absolute color: Yxy; color difference: $\Delta(Yxy)$
Display	External: LCD; 3 values (Y, x, and y) of 3 digits each with additional indications Viewfinder: 3-digit LCD (showing luminance value Y) with LED backlight
Data communication	RS-232C; baud rate: 4800bps
External control	Measurement process can be started by external device connected to data output terminal
Power source	One 9V battery; power can also be supplied via data output terminal
Operating temperature /humidity range	0 to 40°C, relative humidity 85% or less (at 35°C) with no condensation
Storage temperature/humidity range	-20 to 55°C, relative humidity 85% or less (at 35°C) with no condensation
Dimensions	79x208x154mm (3-1/8x8-3/16x6-1/16 in.)
Weight	890g (2 lb.) without battery
Standard accessories	Lens cap; Eyepiece cap; Protective filter, ND eyepiece filter; 9V battery; Chromaticity chart; Case

Specifications are subject to change without notice.

OPTIONAL ACCESSORIES

SYSTEM DIAGRAM (Optional Accessories)

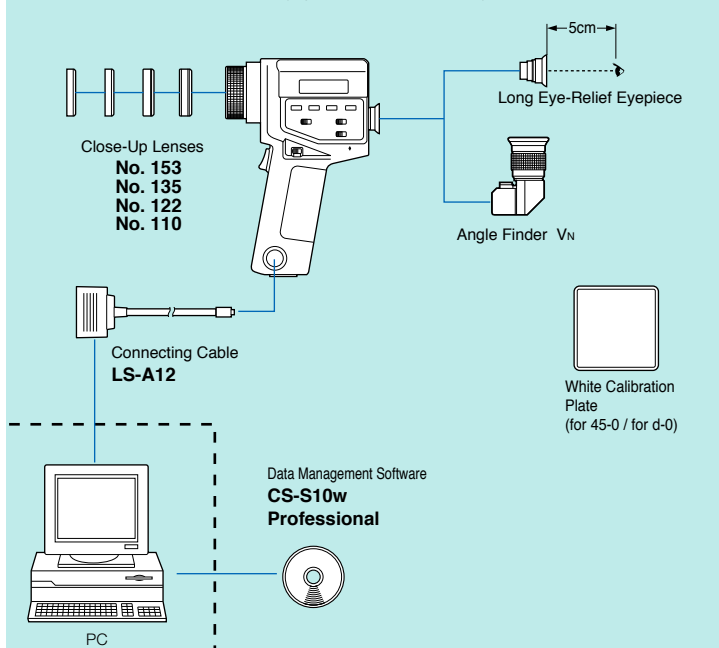

Close-Up Lenses

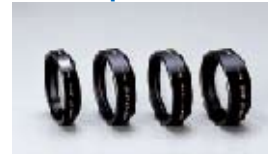

Close-Up Lenses	Minimum measuring area
No.153	ø8.0mm
No.135	ø5.2mm
No.122	ø3.2mm
No.110	ø1.3mm

Long Eye-Relief Eyepiece



When the Long Eye-Relief Eyepiece is used, the measuring area and measurement display inside the viewfinder can be seen with the eye 5cm (2 in.) away from the eyepiece.

Angle Finder Vn



Angle Finder Vn allows the measuring area and measurement display inside the viewfinder to be seen at an angle of 90° to the normal viewfinder optical axis. Angle Finder Vn can also be focused and the magnification can be set to 1x or 2x.

Data Management Software CS-S10w Professional (Optional accessory)

- Color space** : L_v x y, L_v u' v', L_vTΔuv, XYZ, dominant wavelength
- Mode selection** : Normal mode, Object color mode, Contrast mode
RGB mode, RGB & contrast mode
- Instrument control** : Average measurement, Interval measurement
- Data management** : Reading and saving files, Data management with folders
Creating, saving and loading templates (customizable design/layouts for various graphs)
Various graph displays
- Data evaluation** : Observer/Illuminant settings
Statistics display for each folder
Box tolerance setting, Multiple-point measurement, uniformity display, contrast display and polygon tolerance setting for display evaluation
- Other** : Creating reports in customizable screen layouts

System requirements

OS	Windows®2000 Professional SP4, Windows®XP Professional SP2, Windows®XP Professional x64 Edition
CPU	Pentium®III 600 MHz equivalent or higher (recommended)
Memory	128 MB min. (256 MB or more recommended)
Hard disk	60 MB or more space required for installation
Display	1024 X 768, 256 colors or more
Other	CD-ROM drive, USB port

• Windows® are trademarks of Microsoft Corporation in the USA and other countries.
• Pentium® is a trademarks of Intel Corporation in the USA and other countries.

DIMENSIONS

Units:mm

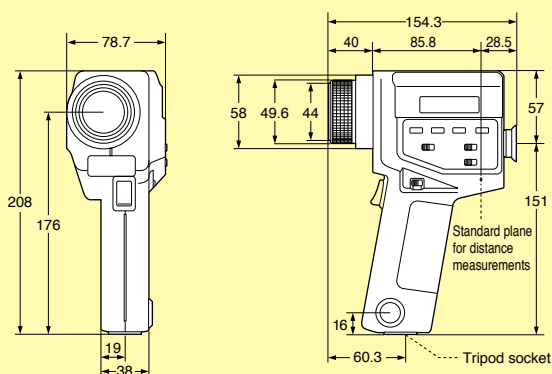



KONICA MINOLTA

SAFETY PRECAUTIONS

For correct use and for your safety, be sure to read the instruction manual before using the instrument.



- Always connect the instrument to the specified power supply voltage. Improper connection may cause a fire or electric shock.
- Be sure to use the specified batteries. Using improper batteries may cause a fire or electric shock.



Certificate No : YKA 0937154
Registration Date : March 3, 1995



Certificate No : JQA-E-80027
Registration Date : March 12, 1997

KONICA MINOLTA SENSING, INC.
Konica Minolta Sensing Americas, Inc
Konica Minolta Sensing Europe B.V.

Osaka, Japan
New Jersey, U.S.A.
European Headquarter /BENELUX
German Office
French Office
UK Office
Italian Office
Belgian Office
Swiss Office
Nordic Office
Austrian Office
Polish Office

Phone : 888-473-2656(in USA), 201-236-4300(outside USA)

Fax : 201-785-2482

Nieuwegein, Netherland
München, Germany
Roissy CDG, France
Milton Keynes, United Kingdom
Milan, Italy
Zaventem, Belgium
Dietikon, Switzerland
Västra Frölunda, Sweden
Wien, Austria
Wroclaw, Poland

Phone : +31(0)30 248-1193
Phone : +49(0)89 630267-9700
Phone : +33(0)1 493-82519
Phone : +44(0)1908 540-622
Phone : +39 02 39011.425
Phone : +32 (0)2 7170 933
Phone : +41(0)43 322-9800
Phone : +46(0)31 7099464
Phone : +43(0)1 87882-430
Phone : +48(0)71 33050-01

Fax : +31(0)30 248-1280
Fax : +49(0)89 630267-9799
Fax : +33(0)1 493-84771
Fax : +44(0)1908 540-629
Fax : +39 02 39011.223
Fax : +32 (0)2 7170 977
Fax : +41(0)43 322-9809
Fax : +46(0)31 474945
Fax : +43(0)1 87882-431
Fax : +48(0)71 33050-01

Konica Minolta (CHINA) Investment Ltd. SE Sales Division
SE Beijing Office
SE Guangzhou Office

Shanghai, China
Beijing, China
Guangzhou, China
Singapore
Seoul, Korea

Phone : +86-021-5489 0202
Phone : +86-010-8522 1551
Phone : +86-020-3826 4220
Phone : +65 6563-5533
Phone : +82(0)2-523-9726

Fax : +86-021-5489 0005
Fax : +86-010-8522 1241
Fax : +86-020-3826 4223
Fax : +65 6560-9721
Fax : +82(0)2-523-9729

Konica Minolta Sensing Singapore Pte Ltd.
KONICA MINOLTA SENSING, INC. Seoul Office

Addresses and telephone/fax numbers are subject to change without notice. For the latest contact information, please refer to the KONICA MINOLTA SENSING Worldwide Offices web page :

<http://konicaminolta.com/instruments/about/network>